

Bidirectional On-Board Charger with Embedded DC/DC Converter

Function

- Charging vehicle battery with AC power
- Power supply to AC load with vehicle battery
- Feeding 12V power from the voltage of vehicle battery

Feature

- Integrating 3 power supply units
- Sharing circuit parts
- Sharing a cooling function and a housing

Performance/Specification

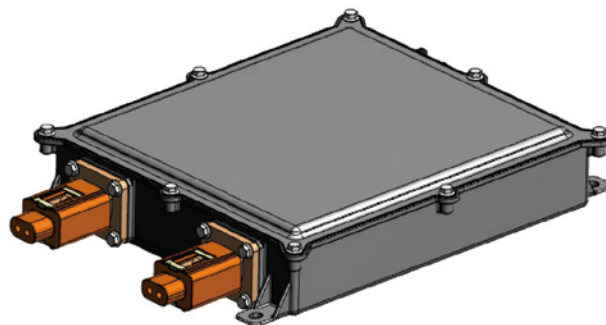

Specification

	On-Board Charger (AC/DC) (7.2kW)	AC Inverter (DC/AC) (1.5kW)	DC/DC Converter (1.5kW)
Input voltage	100V - 240V	200V - 450V	200V - 450V
Output voltage	200V - 450V	100V - 240V	10.5V - 16V